

# CURIOSITY AT HOME

## COLOR MY WORLD

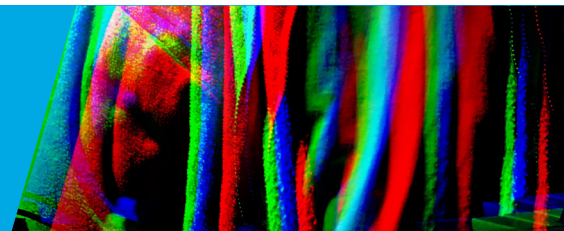

*Objects appear a particular color based on which colors they reflect. A green tree looks green because it reflects green light and absorbs the other colors. If we look at a green tree using a beam of light that does not contain any green, like only red light, the tree would look black because it cannot reflect red light. Make a light box to view different objects in different colors and try this for yourself.*

### MATERIALS

- Empty cardboard box, such as a shoe box
- Black construction paper (or black marker/crayon to color with)
- 4 different colors of transparent, colored plastic large enough, about 6" x 6" square. If you don't have different colors of plastic you can also color in a piece of clear recyclable plastic with a marker. Suggested colors are red, green, blue, and a fourth color of your choice.
- Various small, colored objects that would fit inside the box (including objects that are the same color as the plastic colors).
- Tape (as needed)
- Paper or science notebook
- Pencil

### PROCEDURE

- Line the inside of the box with the black construction paper and tape it into place. If you don't have black construction paper, color the inside of the box with a black marker or crayon.
- Cut a 4" x 4" hole in the lid of the box. On one end of the box, cut a small viewing hole about 1" x 1".
- Place 3–5 small objects in the box, and put the lid on the box with nothing covering the lid hole.
- Look at the objects through the viewing hole. Notice what colors they are and record it in your science notebook. If it's too dark to see the objects, bring the box into a well-lit room or shine a light into the lid hole.
- Place one of the colored plastic pieces over the lid hole and look through the viewing hole again.
- Repeat this process for all the plastic pieces and observe the color of each of the objects.

*Experiment continued on next page...*



Show us how you're being curious! Share your results with us.

Cut out 4"x4" hole

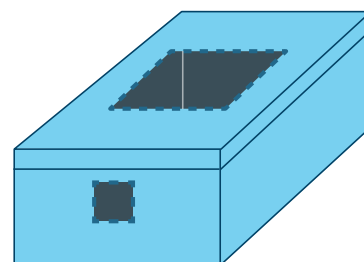
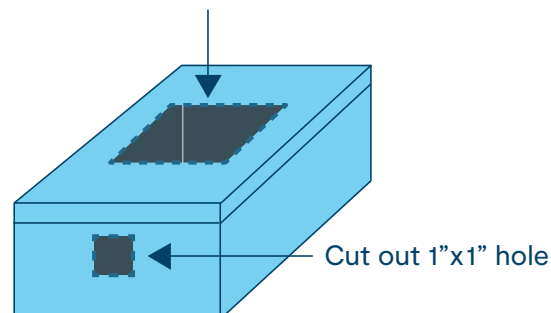

View objects first **without** colored plastic.

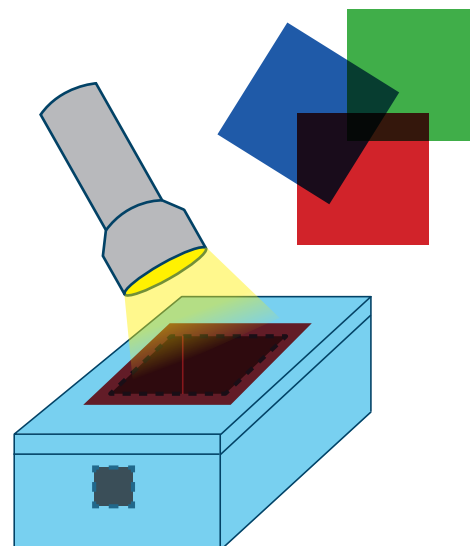

Now view objects **with** each color plastic.

PACIFIC  
SCIENCE  
CENTER



# CURIOSITY AT HOME

## COLOR MY WORLD

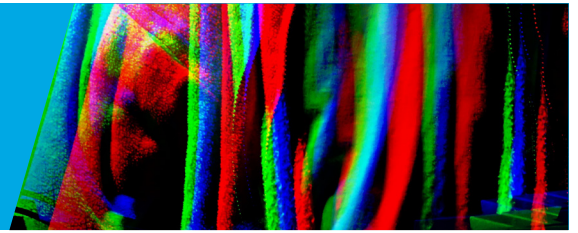

### DID YOU KNOW

When we see an object as a certain color, we are seeing it that way because the object reflects that color of light. Our eyes can only see a small amount of the light that exists. This is called the visible light spectrum and every color of light that you can see falls into this category. Cells in our eyes act as receptors for this type of light and send a message to our brain, showing us that a tree may be green or the ocean is blue.

### Visible Light Spectrum



Show us how you're being curious! Share your results with us.

PACIFIC  
SCIENCE  
CENTER



# CURIOSITY AT HOME

## COLOR MY WORLD

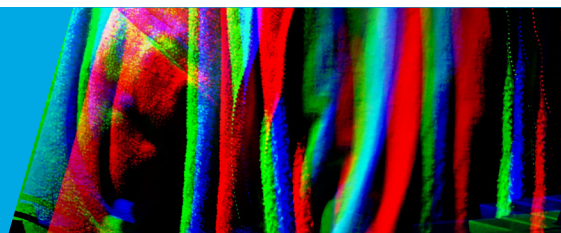

### 6–8 GRADE EXPLORATION

Use the following table or your science notebook to record your observations:

Object	Original Color of Object	Color of object with red plastic	Color of object with green plastic	Color of object with blue plastic	Color of Object with _____ Plastic

- Do the colors of the objects look the same as they did with no plastic? How are they different?
- Find an object in the box that is the same color as the plastic covering the top. What color does it appear to be?
- What would happen if you tried different colors of plastic?
- What would happen if you combined two colors of plastic?
- Change the amount of light shining into the box by partially covering the hole in the top of the box or bringing the box closer or further away from a light. How does this affect the color of the objects within the box?
- For additional exploration, use the plastic on its own and look at objects both near and far away. How do the colors of these objects look the same as they did with no plastic? How are they different?
- How does visible light relate to color? Learn more with NASA: [https://science.nasa.gov/ems/09\\_visiblelight](https://science.nasa.gov/ems/09_visiblelight)
- Learn how the human brain sees visible light with National Geographic: <https://www.nationalgeographic.org/media/visible-light/>
- Want to do another activity? Try out Poking Fun at Color Mixing from the Exploratorium. Note: if you don't have red, green, or blue lights, you can also reuse your plastic used to complete this activity. Just make sure you don't attach your plastic too close to a light, as depending on the lightbulb, it could get hot: <https://www.exploratorium.edu/snacks/poking-fun-at-color-mixing>



Show us how you're being curious! Share your results with us.

